

# Waveguide Step Transition, WR284 to WR340

GERLING

## Model GA2002

GAE offers a series of high power waveguide step transitions that deliver high performance at high power levels. Each model in the series is designed using the quarter wave impedance transformer and mean height methods to achieve near perfect waveguide transitioning.

The model GA2002 transitions between WR284 and WR340 waveguide and accommodates multiple standard flange configurations. Single piece aluminum construction ensures dimensional precision and long life durability.

### General Specifications:

Frequency	2450 MHz +/- 30 MHz
Input Power	6 kW continuous max.
Waveguide Flange	Port 1: WR284 (UG584/U) and CPR284 (UG1725/U) Port 2: WR340 (UG554/U)
Input VSWR	1.02 max.
Insertion Loss	.02 dB max
Construction	Aluminum
Finish	Clear chemical film per MIL-C-5541, Class 1A

### Options:

- ◆ Alternate hole thread sizes
- ◆ Studs on flange hole pattern (any combination)
- ◆ Flange interlock switch
- ◆ Alternate finish

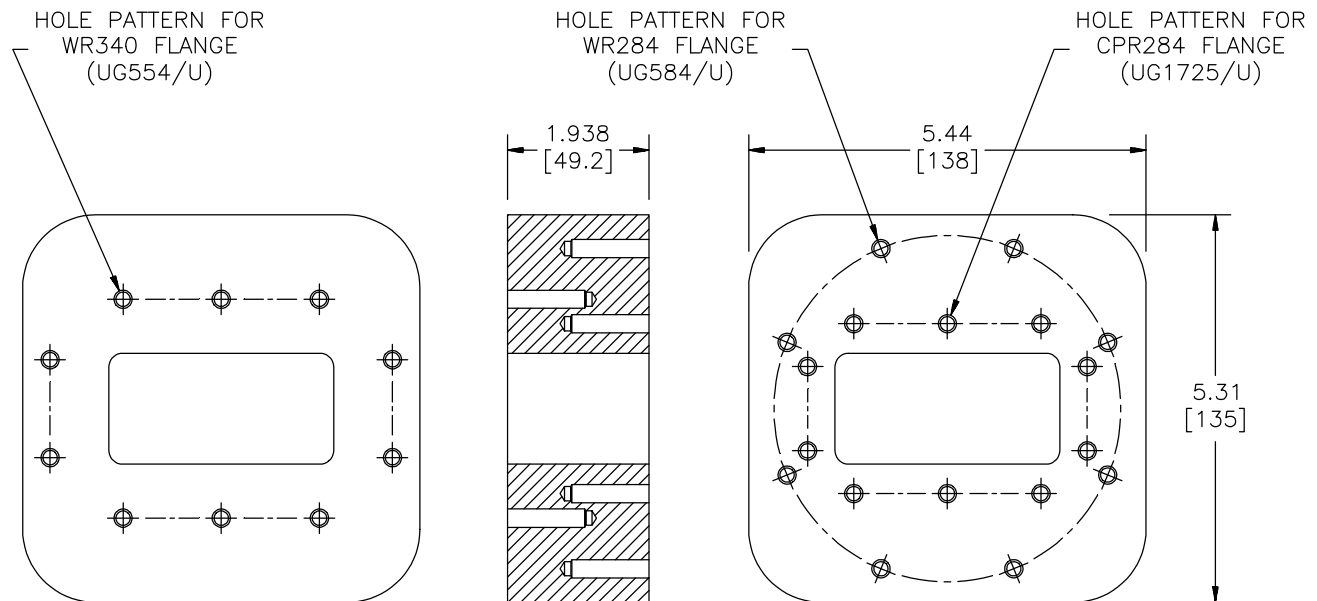
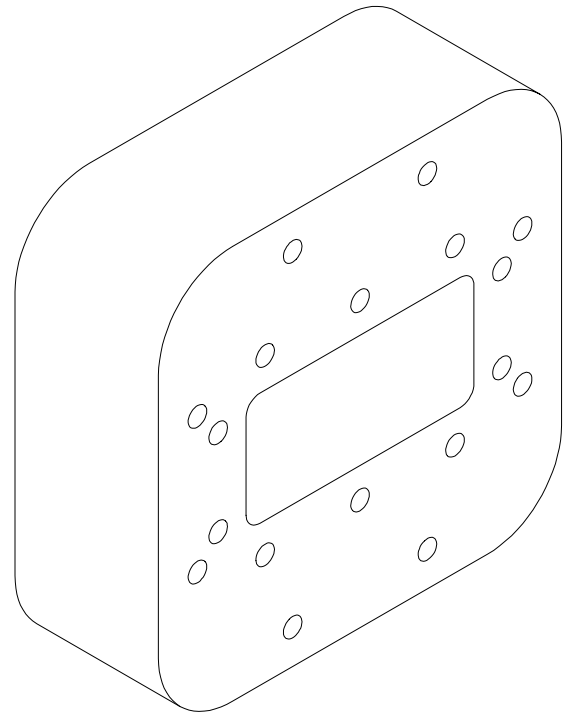

ALL HOLES TAPPED 1/4-20 UNC X 1.00 [25] DP



GERLING APPLIED  
ENGINEERING, INC.

© 2003 Gerling Applied Engineering, Inc.  
PO Box 580816 • Modesto, CA 95358 • USA  
Phone: +1-209-527-8960 • Fax: +1-209-527-5385  
E-mail: sales@2450MHz.com • Web: www.2450MHz.com